

HAMMERTON

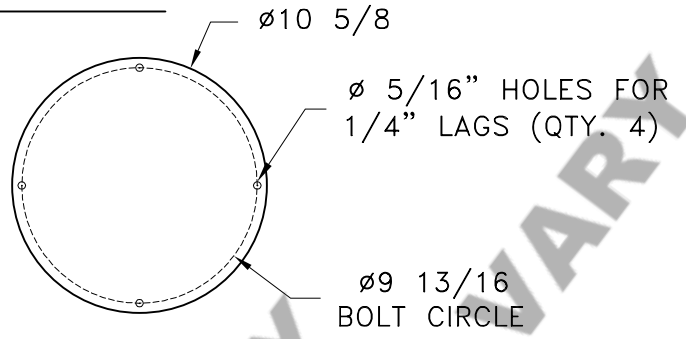

MOUNTING DETAIL

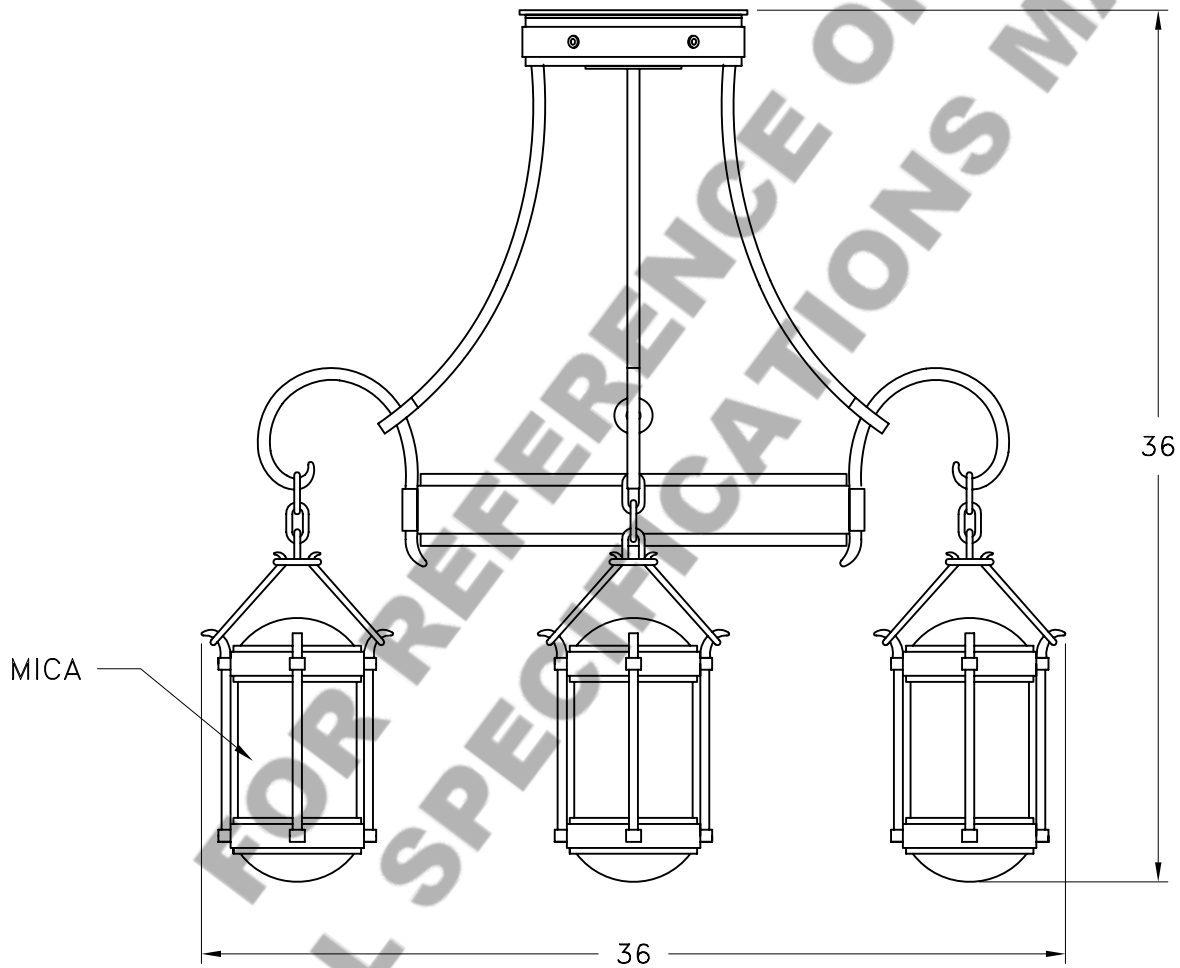

MOUNTING SPECIFICATION NOTES:

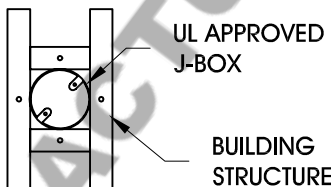

CAUTION

HARDWARE PACKET "A" MOUNTS
 DIRECTLY TO BUILDING STRUCTURE.

ELECTRICAL SPECIFICATION NOTES:



**ELECTRICAL: 4-75 WATT MAX
 EDISON BASE
 120v TYPICAL**

Light Bulb NOT Included

CATALOG # CH9113

APPROXIMATE WEIGHT: 90 Lbs.

HARDWARE PACKET: A

SHADE MATERIAL : MICA

UL RATING: DRY

DIMENSION TOLERANCE $\pm 7/8$ ".

www.hammerton.com

© Copyright 2006, All rights in design, detail or
 invention of this drawing are reserved as the
 property of Hammerton. Any imitation or
 adaptation without written consent is strictly
 prohibited.